

SAXA EDC PENCIL KIT

Kit Features

- Uses .7mm Lead
- Replaceable Eraser (# PK-PCLE10)
- Easy to Turn with Straight Tubes
- Minimal Parts--easy to assemble
- Available in multiple finishes
- Overall Length: 5-13/16"
- Single tube design
- Matches Saxa EDC Pen Kit
- Uses standard slimline pen bushings

Required Accessories

- 7mm Pen Mandrel
- Drill Bit: #PK-7MM for Wood, #PK-7MMSG for Plastic
- Bushing Set (3pc): #PKM-BUSH3 (use any 2)
- Barrel Trimming: #PKTRIM7 or squaring jig on disc sander
- Live Tailstock or Mandrel Saver
- 2 part Epoxy or Thick CA (Cyanoacrylate) Glue
- Pen Blank Minimum Size: 5/8" x 5/8" x 3-1/8"L



Preparing the Blank:

- Cut blank to the length of the tube, adding 1/16" for squaring off.
- Drill 7mm hole lengthwise through the blank.
- Spread glue over tube, insert the tube into the blank with a twisting motion to spread the glue evenly inside.
- Center the tube lengthwise inside the blank.
- When the glue is dry, square the ends of the blanks, making sure the trimmed ends are 90° to the tube. Use a 7mm Barrel Trimmer or a pen blank squaring jig on a disc sander. Take the excess material down flush to the ends of the tubes. Do not trim past the end of the tube since this may interfere with assembly. Use a barrel trimmer to clean the inside of the tube.

DIAGRAM B / TURNING THE BLANK

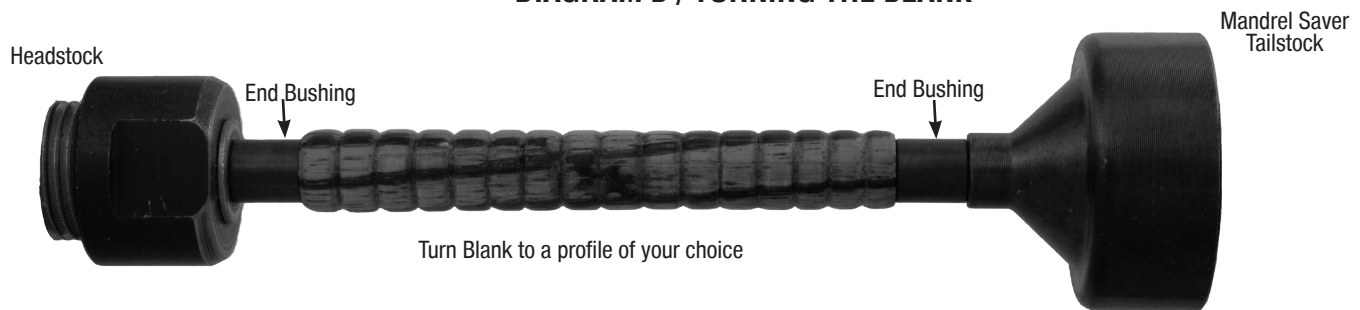

Turning the Blank:

- Mount the bushings and blanks according to diagram B.
- When using Mandrel Saver, there is no need for extra spacer bushings or the knurled nut. Slide and lock tailstock directly against bushings and tighten quill until blank and bushings are secure.
- To use Knurled Nut Setup (right), add spacer bushings until past the threads on the end of the Mandrel Shaft.
- Thread on the Knurled Nut and hand tighten to hold all components in place.
- Slide the Tailstock up snugly against the Mandrel shaft, inserting the live center point into the Mandrel dimple.
- Lock Tailstock and hand tighten the quill adjustment with wheel to steady the mandrel. Do not over-tighten, it could damage mandrel shaft.
- Using sharp tools, turn the blank down close to the bushing diameter. Turn the barrel straight or to a profile of your choice.
- Sand the blank down to be flush with the bushings, gradually increasing sandpaper grits.
- Finish the barrel using your choice of polish. Allow sufficient time for the polish to cure—refer to polish manufacturer's instructions.

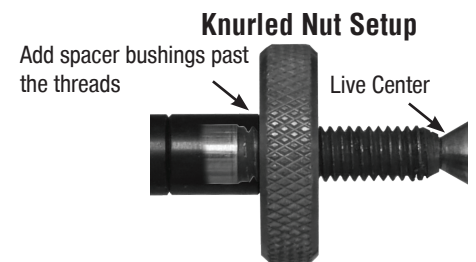

Diagram C / Bushing #PKM-BUSH3
(use any two)

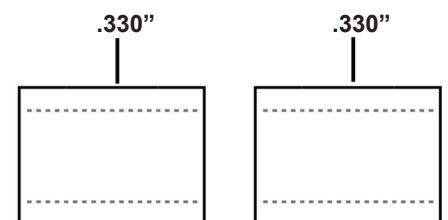
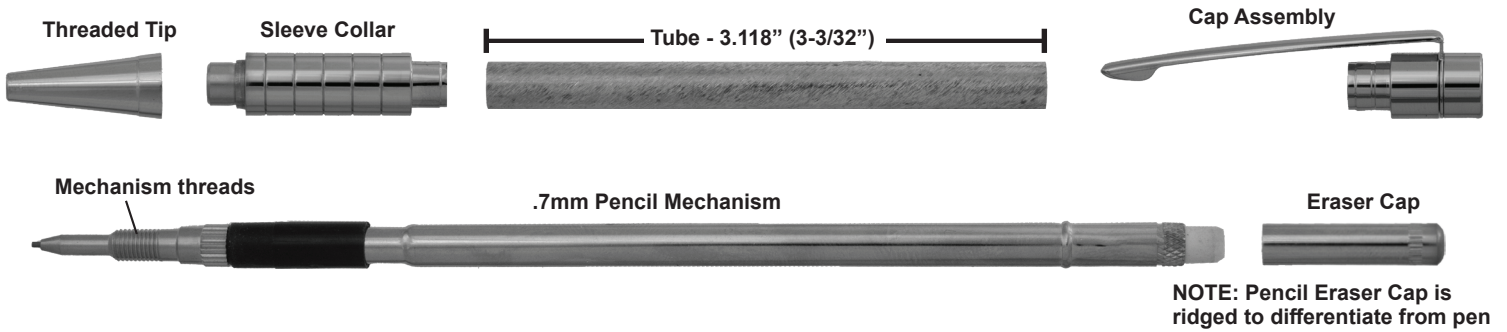

Diagram D / Parts Layout

**Assembly:**

- Press Cap Assembly into upper end of Barrel.
- Press Sleeve Collar into opposite, open end of Barrel.
- Slide Mechanism, with Eraser Cap attached, through the Cap Assembly until threads on Mechanism Tip are visible past the Sleeve Collar.
- Thread Tip onto exposed Mechanism threads until tight.
- To extend lead, push on Eraser Cap. To retract lead, push and hold Eraser Cap and push lead back into mechanism.
- To access Eraser, pull Eraser Cap.
- To add .7mm lead, pull Eraser (with its knurled holder) from the back of the mechanism and load lead into opening in the back of Mechanism. You may have to unthread Tip and pull out Mechanism to get a decent grasp on Eraser.
- Replace Eraser with one from item # PK-PCLE10.